

TEST PROTOCOL – AEB CAR TO CAR

VERSION 2.0
MAY 2024



**ASEAN NCAP
PROTOCOL**

2026–2030

ACTO

Preface

During the test preparation, vehicle manufacturers are encouraged to liaise with the test laboratory and to check that they are satisfied with the way cars are set up for testing. Where a manufacturer feels that a particular item should be altered, they should ask the laboratory staff to make any necessary changes. Manufacturers are forbidden from making changes to any stipulated parameter that will influence the test, such as vehicle setting, test environment etc.

It is the responsibility of the test laboratory to ensure that any requested changes satisfy the requirements of ASEAN NCAP. Where a disagreement exists between the laboratory and manufacturer, the ASEAN NCAP secretariat should be informed immediately to pass final judgement. Where the laboratory staff suspect that a manufacturer has interfered with any of the setup, the manufacturer's representatives should be warned that they are not allowed to do so themselves. They should also be informed that if another incident occurs, they will be asked to leave the test site.

Where there is a recurrence of the problem, the manufacturer's representatives will be told to leave the test site and the Secretariat should be immediately informed.

Any such incident may be reported by the Secretariat to the manufacturer and the persons concerned may not be allowed to attend further ASEAN NCAP tests.

DISCLAIMER: ASEAN NCAP has taken all reasonable care to ensure that the information published in this protocol is accurate and reflects the technical decisions taken by the organisation. In the unlikely event that this protocol contains a typographical error or any other inaccuracy, ASEAN NCAP reserves the right to make corrections and determine the assessment and subsequent result of the affected requirement(s).

In addition to the settings specified in this protocol, the following information will be required from the manufacturer of the car being tested in order to facilitate the vehicle preparation. A vehicle handbook should be provided to the test laboratory prior to preparation.

TEST PROTOCOL – AEB SYSTEMS

Table of Contents

1	INTRODUCTION.....	2
2	DEFINITIONS.....	3
3	REFERENCE SYSTEM.....	5
4	MEASURING EQUIPMENT.....	7
5	EURO NCAP VEHICLE TARGET.....	9
6	TEST CONDITIONS.....	10
7	TEST PROCEDURE.....	15
	ANNEX A.....	23
	ANNEX B.....	34

NEW CAR ASSESSMENT PROGRAM FOR SOUTHEAST ASIAN COUNTRIES (ASEAN NCAP)

TEST PROTOCOL – AEB SYSTEMS

1 INTRODUCTION

Car-to-car rear impacts remain one of the most frequent road traffic accidents in Southeast Asia as a result of driver distraction or misjudgement.

Typical crashes during city driving normally occur at relatively low speeds where the impacted car is stationary, but with a high risk of a debilitating whiplash injury to the driver of the struck vehicle. While injury severities are usually low, these accidents are very frequent and represent over a quarter of all crashes.

Similar accident scenarios occur on the open road at moderate to higher speeds, where a driver might be distracted and may fail to recognize that the traffic in front of him has stopped, coming to a halt or is at a lower speed.

To support the driver in avoiding nose-to-tail crashes, car manufacturers offer avoidance technology that warns, supports adequate braking and/or ultimately stops the vehicle. The systems that work mostly at lower speed are referred to as AEB City systems whereas those that function at higher speed are called AEB Inter-Urban systems.

This protocol specifies the AEB City and AEB Inter-Urban test procedures which are part of the Safety Assist assessment, respectively. For AEB City, the Car-to-Car Rear Stationary

(CCRs) scenario is applicable, in which the AEB functionality at lower speed is tested.

For AEB Inter-Urban, the system is tested in two scenarios i.e., Car-to-Car Rear Moving (CCRm) and Car-to-Car Rear Braking (CCRb). For this type of AEB system, the AEB functionality at higher speed is assessed.

2 DEFINITIONS

In this protocol, references are made to the following terms, namely:

Peak Braking Coefficient (PBC) – the measure of tyre to road surface friction based on the maximum deceleration of a rolling tyre, measured using the American Society for Testing and Materials (ASTM) E1136-19 (2019) standard reference test tyre, in accordance with ASTM Method E1337-2019, at a speed of 64.4 km/h, without water delivery.

Autonomous Emergency Braking (AEB) – braking that is applied automatically by the vehicle in response to the detection of a likely collision to reduce the vehicle speed and potentially avoid the collision.

Dynamic Brake Support (DBS) – a system that further amplifies the driver braking demand in response to the detection of a likely collision to achieve a greater deceleration than would otherwise be achieved for the braking demand in normal driving conditions.

Car-to-Car Rear Stationary (CCRs) – a test scenario in which a vehicle travels forwards towards another stationary vehicle.

Car-to-Car Rear Moving (CCRm) – a test scenario in which a vehicle travels forwards towards another vehicle that is travelling at a constant speed.

Car-to-Car Rear Braking (CCRb) – a test scenario in which a vehicle travels forwards towards another vehicle that is travelling at a constant speed and then decelerates.

Vehicle Under Test (VUT) – the subject vehicle tested according to this protocol with a pre-crash collision mitigation or avoidance system on board.

EURO Vehicle Target (EVT) – the vehicle target used in this protocol to construct the AEB test scenarios.

Vehicle width – the widest point of the vehicle ignoring the rear-view mirrors, side marker lamps, tyre pressure indicators, direction indicator lamps, position lamps, flexible mudguards, and the deflected part of the tyre side-walls immediately above the point of contact with the ground.

Time To Collision (TTC) – the remaining time before the VUT strikes the EVT, assuming that the VUT and EVT would continue to travel with the speed it is travelling.

T_{AEB} – the time where the AEB system activates. The activation time is determined by identifying the last data point where the filtered acceleration signal is less than -1 m/s^2 , and then returning to the point in time where the acceleration first crossed -0.3 m/s^2 .

T_{FCW} – the time where the audible warning of the FCW starts. The starting point is determined by audible recognition.

V_{impact} – the speed at which the VUT hits the EVT.

$V_{\text{rel_impact}}$ – the relative speed at which the VUT hits the EVT by subtracting the velocity of the EVT from V_{impact} at the time of collision.

3 REFERENCE SYSTEM

3.1 Convention

3.1.1 For both VUT and EVT, ASEAN NCAP shall use the convention specified in ISO 8855:2011 in which the x-axis points toward the front of the vehicle, the y-axis toward the left and the z-axis upward (right-hand system), with the origin at the most forward point on the centreline of the VUT for dynamic data measurements as shown in Figure 1.

3.1.2 Viewed from the origin, roll, pitch and yaw rotate clockwise around the x, y and z axes respectively. Longitudinal refers to the component of the measurement along the x-axis, lateral the component along the y-axis and vertical of the component along the z-axis.

3.1.3 This reference system should be used for both left-hand and right-hand drive vehicles tested.

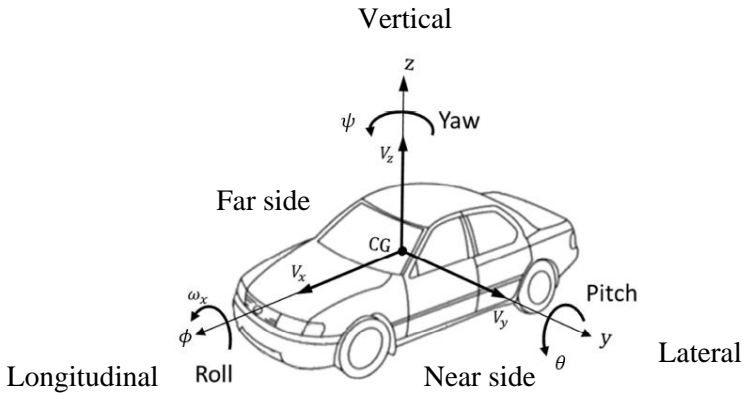

Figure 1: Coordinate system and notation

3.2 Lateral Offset

3.2.1 The lateral offset is determined as the lateral distance between the centre of the front of the VUT and the centre of the rear of the EVT when measured in parallel to the intended straight-lined path as shown in the figure below.

$$\text{Lateral offset} = Y_{\text{VUT error}} + Y_{\text{EVT error}}$$

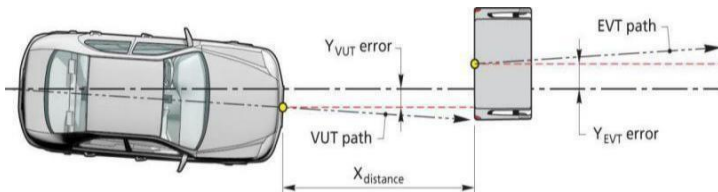

Figure 2: Lateral offset

4 MEASURING EQUIPMENT

4.1 Sample and record

A sample and record of all dynamic data at a frequency of at least 100 Hz are kept. They shall be synchronised using the DGPS time stamp the EVT data with that of the VUT.

4.2 Measurements and Variables

4.2.1 Time

- Time of test start, T_0 equals $TTC = 4$ s **T**
T₀
- T_{AEB} , time where AEB activates **T_{AEB}**
- T_{FCW} , time where FCW activates **T_{FCW}**
- T_{impact} , time where VUT impacts EVT **T_{impact}**

4.2.2 Position of the VUT during the entire test

X_{VUT}, Y_{VUT}

4.2.3 Position of the EVT during the entire test

X_{EVT}, Y_{EVT}

4.2.4 Speed of the VUT during the entire test

- V_{impact} , speed when VUT impacts EVT **V_{VUT}**
V_{impact}
- V_{rel_impact} , relative speed when VUT impacts EVT **V_{rel_impact}**

4.2.5 Speed of the EVT during the entire test

V_{EVT}

4.2.6 Yaw velocity of the VUT during the entire test

4.2.7 Yaw velocity of the EVT during the entire test

4.2.8 Acceleration of the VUT during the entire test A_{VUT}

4.2.9 Acceleration of the EVT during the entire test A_{EVT}

4.3 Measuring Equipment

4.3.1 Equip the VUT with data measurement and acquisition equipment and EVT with data measurement to sample and record data with an accuracy of at least:

- VUT and EVT speed of 0.1 km/h;
- VUT and EVT lateral and longitudinal position to 0.03 m;
- VUT and EVT yaw rate to 0.1°/s;
- VUT and EVT longitudinal acceleration to 0.1 m/s²;
- VUT steering wheel velocity to 1.0°/s.

4.4 Data Filtering

4.4.1 Filter the measured data as follows:

4.4.1.1 Position and speed are not filtered and are used in their raw state.

4.4.1.2 Acceleration, yaw rate and VUT steering wheel velocity with a 12-pole phaseless Butterworthfilter with a cut off frequency of 10 Hz.

5 EURO NCAP VEHICLE TARGET

5.1 Specification

5.1.1 Conduct the tests in this protocol using the EURO NCAP Vehicle Target V1 (EVT) as shown in Figure 3 below. The EVT replicates the visual, radar, LIDAR and PMD attributes of a typical M₁ passenger vehicle and is impactable at differential speeds up to 50 km/h without causing damage to the EVT.



Figure 3: Euro NCAP Vehicle Target (EVT)

5.1.2 To ensure repeatable results, the propulsion system and EVT must meet the requirements as detailed in ANNEX A.

5.1.3 The EVT is designed to work with the following types of sensors:

Radar (24 and 77 GHz)

LIDAR

Camera

PMD

Where a manufacturer believes that the EVT is suitable for another type of sensor system other than used by the VUT but is not listed above, the manufacturer is asked to contact the ASEAN NCAP Secretariat.

6 TEST CONDITIONS

6.1 Test Track

6.1.1 Conduct tests on a dry (no visible moisture on the surface), uniform, solid-paved surface with a consistent slope between level and 1%. The test surface shall have a minimal peak braking coefficient (PBC) of 0.9.

6.1.2 The surface must be paved and may not contain any irregularities (e.g., large dips or cracks, manhole covers or reflective studs) that may give rise to abnormal sensor measurements within a lateral distance of 3.0 m to either side of the test path and with a longitudinal distance of 30 m ahead of the VUT when the test ends.

6.1.3 The presence of lane markings is allowed. However, testing may only be conducted in an area where typical road markings depicting a driving lane may not be parallel to the test path within 3.0 m on either side. Lines or markings may cross the test path but may not be present in the area where AEB activation is expected.

6.2 Weather Conditions

6.2.1 Conduct tests in dry conditions with ambient temperature above 5°C and below 40°C.

6.2.2 No precipitation shall be falling and horizontal visibility at ground level shall be greater than 1km. Wind speeds shall be below 10 m/s to minimize EVT and VUT disturbance.

6.2.3 Natural ambient illumination must be homogenous in the test area and more than 2000 lux for daylight testing with no strong shadows cast across the test area other than those caused by the VUT or EVT. Ensure testing is not performed driving towards, or away from the sun when there is direct sunlight.

6.2.4 Measure and record the following parameters preferably at the commencement of every single test:

- a) Ambient temperature in °C;
- b) Track Temperature in °C;
- c) Wind speed and direction in m/s;
- d) Ambient illumination in Lux.

6.3 Surroundings

6.3.1 Conduct testing such that there are no other vehicles, highway furniture, obstructions, other objects or persons protruding above the test surface that may give rise to abnormal sensor measurements within a lateral distance of 3.0 m to either side of the test path and within a longitudinal distance of 30 m ahead of the VUT when the test ends (Figure 4).

6.3.2 Test areas where the VUT needs to pass under overhead signs, bridges, gantries or other significant structures are not permitted.

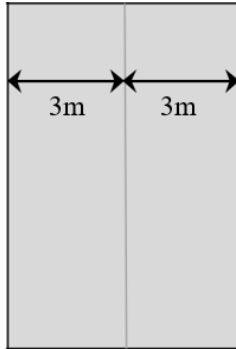

Figure 4: Free surroundings requirement

6.3.3 The general view ahead and to either side of the test area shall comprise a wholly plain man-made or natural environment (e.g., further test surface, plain coloured fencing or hoardings, natural vegetation or sky etc.) and must not comprise any highly reflective surfaces or contain any vehicle-like silhouettes that may give rise to abnormal sensor measurements.

6.4 VUT Preparation

6.4.1 AEB and FCW System Settings

6.4.1.1 Set any driver configurable elements of the AEB and/or FCW system (e.g., the timing of the collision warning or the braking application if present) to the middle setting or midpoint and the next latest setting similar to the examples shown in Figure 5.

6.4.1.2 When the vehicle is equipped with a Driver State Monitoring (DSM) which alters the AEB and/or FCW sensitivity according to the driver's state (e.g. distracted / attentive), this

system shall be deactivated before the testing commences.

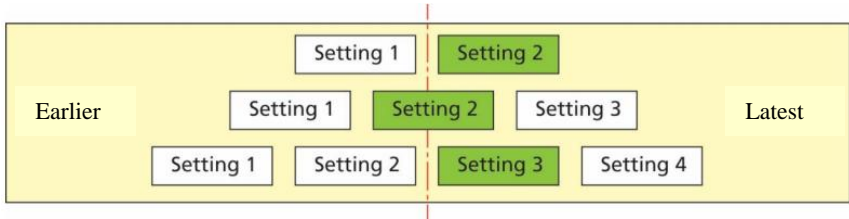

Figure 5: AEB and/or FCW system setting for testing

6.4.2 Tyres

Perform the testing with new original fitment tyres of the make, model, size, speed and load rating as specified by the vehicle manufacturer. It is permitted to change the tyres which are supplied by the manufacturer or acquired at an official dealer representing the manufacturer if those tyres are identical in make, model, size, speed and load rating to the original fitment. Inflate the tyres to the vehicle manufacturer's recommended cold tyre inflation pressure(s). Use inflation pressures corresponding to the least loading normal condition.

Run-in tyres according to the tyre conditioning procedure specified in 7.1.3. After running-in maintain the run-in tyres in the same position on the vehicle for the duration of the testing.

6.4.3 Wheel Alignment Measurement

The vehicle should be subject to a vehicle (in-line) geometry check to record the wheel alignment set by the OEM. This should be done with the vehicle in kerb weight.

6.4.4 Unladen Kerb Mass

6.4.4.1 Fill up the tank with fuel to at least 90% of the tank's capacity of fuel.

6.4.4.2 Check the oil level and top up to its maximum level if necessary. Similarly, top up the levels of all other fluids to their maximum levels if necessary.

6.4.4.3 Ensure that the vehicle has its spare wheel on board, if fitted, along with any tools supplied with the vehicle. Nothing else should be in the car.

6.4.4.4 Ensure that all tyres are inflated according to the manufacturer's instructions for the appropriate loading condition.

6.4.4.5 Measure the front and rear axle masses and determine the total mass of the vehicle. The total mass is the 'unladen kerb mass' of the vehicle. Record this mass in the test details.

6.4.4.6 Calculate the required ballast mass, by subtracting the mass of the test driver and test equipment from the required 200 kg interior load.

6.4.5 Vehicle Preparation

6.4.5.1 Fit the on-board test equipment and instrumentation in the vehicle. Also fit any associated cables, cabling boxes and power sources.

6.4.5.2 Place weights with a mass of the ballast mass. Any items

added should be securely attached to the car.

6.4.5.3 With the driver in the vehicle, weigh the front and rear axle loads of the vehicle.

6.4.5.4 Compare these loads with the “unladen kerb mass”.

6.4.5.5 The total vehicle mass shall be within $\pm 1\%$ of the sum of the unladen kerb mass, plus 200 kg. The front/rear axle load distribution needs to be within 5% of the front/rear axle load distribution of the original unladen kerb mass plus full fuel load. If the vehicle differs from the requirements given in this paragraph, items may be removed or added to the vehicle which has no influence on its performance. Any items added to increase the vehicle mass should be securely attached to the car.

6.4.5.6 Repeat paragraphs 6.4.5.3 and 6.4.5.4 until the front and rear axle loads and the total vehicle mass are within the limits set in paragraph 6.4.5.5. Care needs to be taken when adding or removing weight in order to approximate the original vehicle inertial properties as close as possible. Record the final axle loads in the test details. Record the axle weights of the VUT in the ‘as tested’ condition.

7 TEST PROCEDURE

7.1 VUT Pre-test Conditioning

7.1.1 General

7.1.1.1 A car is used as delivered to the test laboratory.

7.1.1.2 If requested by the vehicle manufacturer, drive a maximum of 100 km on a mixture of urban and rural roads with other traffic and roadside furniture to ‘calibrate’ the sensor system. Avoid harsh acceleration and braking.

7.1.2 Brakes

7.1.2.1 Condition the vehicle’s brakes in the following manner:

- Perform ten stops from a speed of 56 km/h with an average deceleration of approximately 0.5 to 0.6 g.
- Immediately following the series of 56 km/h stops, perform three additional stops from a speed of 72 km/h, each time applying sufficient force to the pedal to operate the vehicle’s antilock braking system (ABS) for the majority of each stop.
- Immediately following the series of 72 km/h stops, drive the vehicle at a speed of approximately 72 km/h for five minutes to cool the brakes.
- Initiation of the first test shall begin within two hours after completion of the brake conditioning.

7.1.3 Tyres

7.1.3.1 Condition the vehicle’s tyres in the following manner to remove the mould sheen:

- Drive around a circle of 30 m in diameter at a speed sufficient to generate a lateral acceleration of approximately 0.5 to 0.6 g for three clockwise laps followed by three anticlockwise laps.
- Immediately following the circular driving, drive four

passes at 56 km/h, performing ten cycles of a sinusoidal steering input in each pass at a frequency of 1 Hz and amplitude sufficient to generate a peak lateral acceleration of approximately 0.5 to 0.6 g.

- Make the steering wheel amplitude of the final cycle of the final pass double that of the previous inputs.

7.1.3.2 In case of instability in the sinusoidal driving, reduce the amplitude of the steering input to an appropriately safe level and continue the four passes.

7.1.4 AEB System Check

7.1.4.1 Before any testing begins, perform a maximum of ten runs at the lowest test speed the system is supposed to work, to ensure proper functioning of the system.

7.2 Test Scenarios

7.2.1 The performance of the VUT AEB system is assessed in the CCRs, CCRm and CCRb scenarios as shown in Figures 6.1 to Figure 6.3.

7.2.2 For testing purposes, assume a straight-line path equivalent to the centreline of the lane in which the collision occurred, hereby known as the test path. Control the VUT with driver inputs or use alternative control systems that can modulate the vehicle controls as necessary to perform the tests.

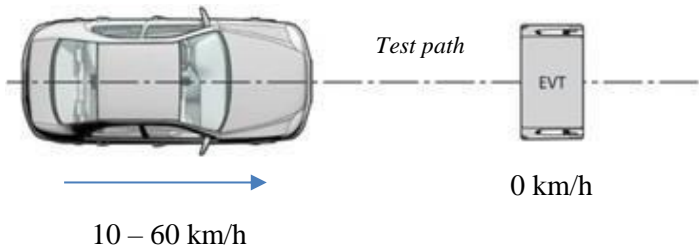

Figure 6.1: CCRs scenario

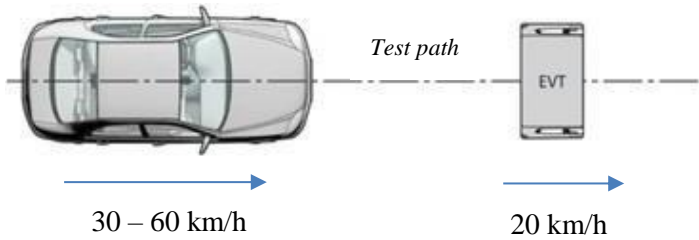

Figure 6.2: CCRm scenario

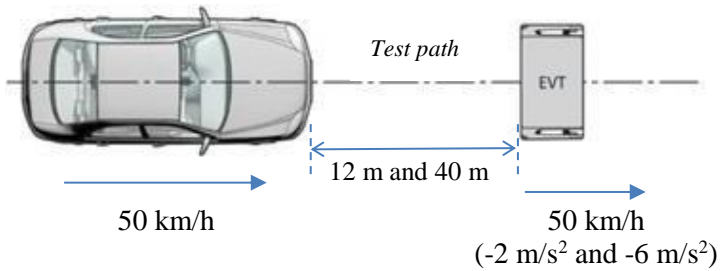

Figure 6.3: CCRb scenario

7.2.3 For AEB systems tests, when there is complete avoidance, the subsequent test speed for the next test is increased by 10

km/h. When there is contact, first perform a test at a test speed of 5 km/h less than the test speed where contact occurred. After this, continue to perform the remainder of the tests with speed increments of 5 km/h by repeating sections 8.3.1 to 8.4.3. Stop testing when the speed reduction seen in the test is less than 5 km/h. The CCRs, CCRm and CCRb tests will be performed within the reference speed profile shown in the tables below.

Test scenario		AEB ONLY	
CCR _s		10 - 60 km/h	
CCR _m		30 - 60 km/h	
CCR _b	Headway	- 2 m/s ²	-6 m/s ²
	12 m	50 km/h	50 km/h
	40 m	50 km/h	50 km/h

7.2.4 The desired deceleration of the EVT shall be reached within 1.0 seconds and shall not vary by more than $\pm 0.25 \text{ m/s}^2$ of the desired level at any point in time until the end of the test.

7.2.5 For CCR_b $T_0 - T_{\text{EVT_deceleration_start}} - 1\text{s}$.

T_0 begins 1 s before EVT starts deceleration, for tolerance monitoring purposes. The desired deceleration of the EVT shall be reached within 1.0 seconds ($T_0 + 2.0 \text{ s}$) which after the EVT shall remain within $\pm 0.5 \text{ km/h}$ of the reference speed profile, derived from the desired deceleration, until the vehicle speed equals 2 km/h.

7.3 Test Conduct

7.3.1 Before every test run, drive the VUT around a circle of maximum diameter 30 m at a speed less than 10 km/h for one

clockwise lap followed by one anticlockwise lap, and then maneuver the VUT into position on the test path. If requested by the OEM, an initialisation run may be included before every test run. Bring the VUT to a halt and push the brake pedal through the full extent of travel and release.

7.3.2 For vehicles with an automatic transmission, select D. For vehicles with a manual transmission, select the highest gear where the RPM will be at least 1500 at the test speed. If fitted, a speed limiting device or cruise control may be used to maintain the VUT speed unless the vehicle manufacturer shows that there are interferences of these devices with the AEB system in the VUT. Apply only minor steering inputs as necessary to maintain the VUT tracking along the test path.

7.3.3 Perform the first test a minimum of 90 s and a maximum of 10 minutes after completing the tyre conditioning, and subsequent tests after the same time period. If the time between consecutive tests exceeds 10 minutes repeat the tyre conditioning procedures and recommence testing.

7.3.4 Between tests, maneuver the VUT at a maximum speed of 50 km/h and avoid riding the brake pedal and harsh acceleration, braking or turning unless strictly necessary to maintain a safe testing environment.

7.4 Test Execution

7.4.1 Accelerate the VUT and EVT (if applicable) to the respective test speeds.

7.4.2 The test shall start at T_0 (4 s TTC) and is valid when

all boundary conditions are met between T_0 and T_{AEB} :

Boundary condition	Remark	VUT	EVT
Speed (km/h)	Constant state	+ 1.0	± 1.0
	Deceleration state	N/A	± 0.5
Lateral deviation from test path (m)		0 ± 0.1 m	0 ± 0.1 m
Relative distance VUT and EVT		12 or 40 m ± 0.5 m	

7.4.3 The end of a test is considered when one of the following occurs:

- $V_{VUT} = 0$ km/h
- $V_{VUT} < V_{EVT}$
- Contact between VUT and EVT

For manual or automatic accelerator control, it needs to be assured that during automatic brake the accelerator pedal does not result in an override of the system.

7.4.4 Braking will be applied that results in a maximum brake level of $-4 \text{ m/s}^2 - 0.25 \text{ m/s}^2$ when applied in a non-threat situation. The particular brake profile to be applied (pedal application rate applied in 200 ms (max. 400 mm/s) and pedal force) shall be specified by the manufacturer. When the brake profile provided by the manufacturer results in a higher brake level than allowed, the iteration steps as described in ANNEX B will be applied to scale the brake level to $-4 \text{ m/s}^2 - 0.25 \text{ m/s}^2$.

7.4.5 When no brake profile is provided, the default brake profile as described in ANNEX B will be applied.

ANNEX A

EVT SPECIFICATIONS

The Euro NCAP Vehicle Target (EVT) which is used for AEB City and Inter-Urban testing is developed to have the radar signature, reflectivity and visual signature comparable to that of a 'C' segment vehicle in order to aid radar, LIDAR, PMD and camera detection respectively.

The EVT is built up out of a balloon structure that is covered by a PVC cover on which a vehicle is printed. For both a detailed description is provided within this ANNEX.

A.1 Balloon Vehicle Structure

The balloon structure consists of polyester, polyethylene, PA 6.6, polychloroprene and nylon. The outer dimensions of the balloon structure are 1600 mm wide and 1350 mm tall with a tolerance of ± 10 mm. More detailed dimensions can be found in the front and side view in Figure A.1.1 and Figure A.1.2.

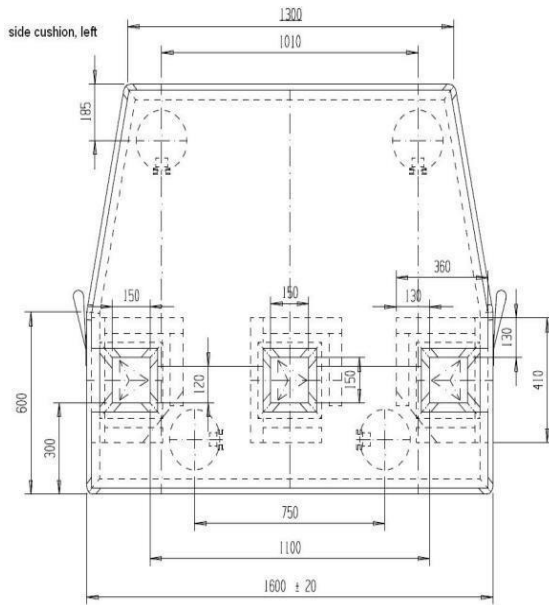

Figure A.1.1: Balloon structure front view

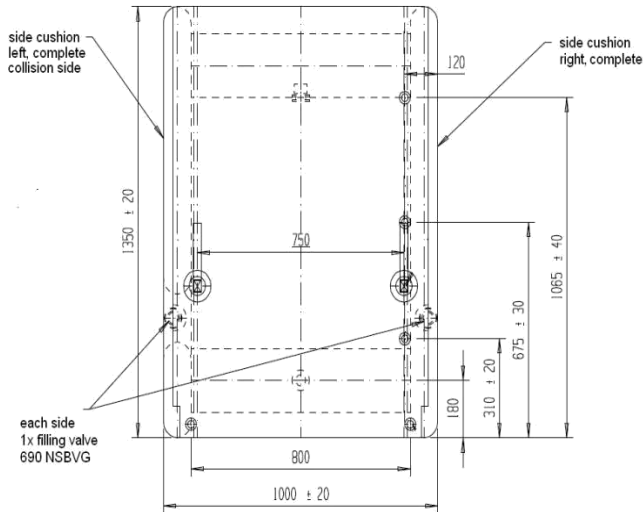

Figure A.1.2: Balloon structure side view

A.1.1 Radar Absorption Mat

At the impact side and rear of the balloon target a layer of radar absorbing material is applied. The exact position and dimensions of these radar absorption mats are shown in Figure A.1.1.1 and Figure A.1.1.2. The material properties of the radar absorption mat are detailed in paragraph A.1.1.1

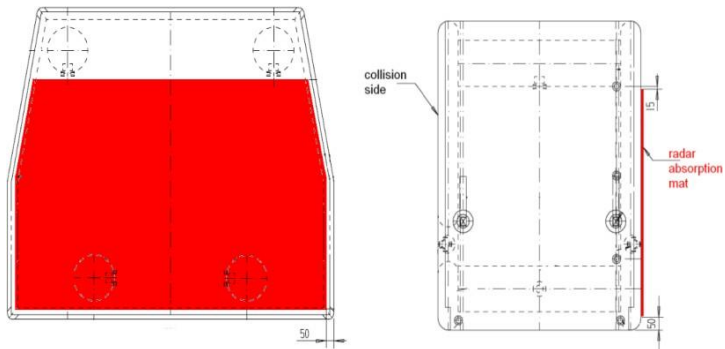

Figure A.1.1.1: Rear and side view of balloon structure including the rear radar absorption mat

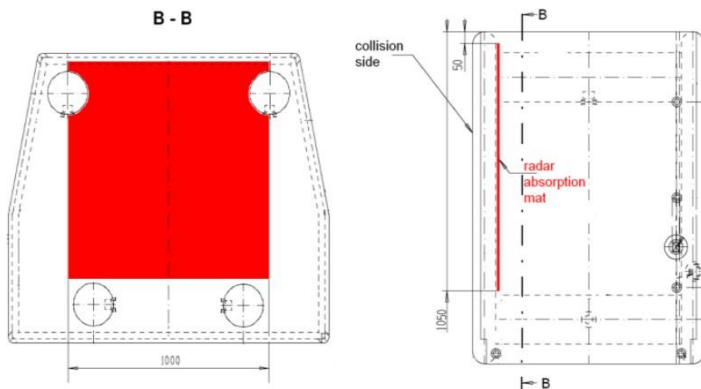

Figure A.1.1.2: Section B-B and side view of balloon structure including the front radar absorption mat

A.1.1.1 Material Properties

The radar absorption mats are according to ASTM-D1692-68 and are made of Polyurethane foam EC 712 with the attenuation in dB as shown in the table below. The absorber can be loaded with 2 mW per mm².

Footprint	Thickness	<1GHz	3 GHz	5 GHz	10 GHz	18 GHz
500x500mm	10mm	---	10	25	35	40

A.1.2 Bumper

At the impact side, a bumper plate is attached to the front of the balloon structure to create a more vehicle-like contour. The dimensions and position of the bumper element are shown in Figure A.1.2.1 and Figure A.1.2.2. The tolerances on the dimensions are ± 10 mm.

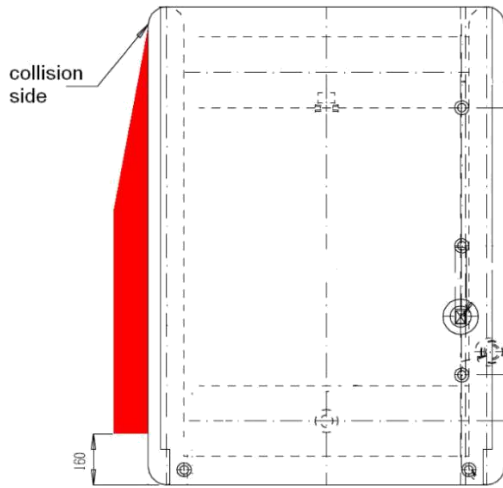

Figure A.1.2.1: Side view of balloon structure including the bumper element

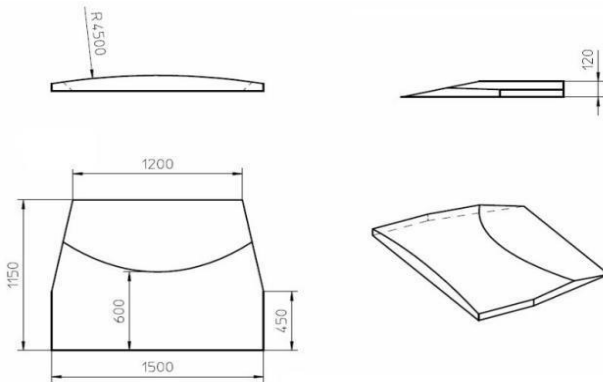

Figure A.1.2.2: Top, side, front and ISO view of bumper element

A.1.3 Radar Reflector

Within the bumper element, a radar reflector is incorporated. The reflector has an inside edge length of 55 mm and imitates a surface of 2.5 m² at 77 GHz. The position and orientation of the radar reflector within the bumper element are shown in Figure A.1.3.1.

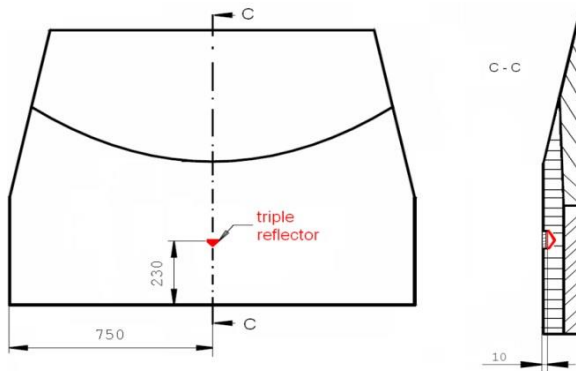

Figure A.1.3.1: Front and side view of the radar reflector within the bumper element

A.1.4 Reflective Film

In addition to the radar reflector, two reflective films of 1360 mm wide and 150 mm high are glued onto the bumper element as shown in Figure A.1.4.1. The films are made of polyester and are provided by Bruin Plastic Company INC (<http://www.bruinplastics.com/index.html>) under the product name of Energy Shield 200-10 oz. If another reflection film is used, the reflection characteristics have to be identical as for the

Energy Shield 200.

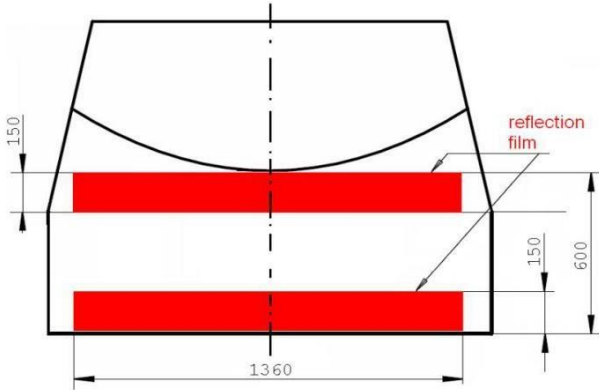

Figure A.1.4.1: Front view of the reflective film on the bumper element

A.2 EVT Outer Cover

The balloon structure is covered by a PVC cover with a picture of an actual car is printed. The cover material is produced by Complot Papier Union (<http://www.complotpapierunion.de/>) with the product name PowerJet Poly Banner Frontlit 550 B1, which is a 550 g/m² tarpaulin.

The generic artwork that needs to be printed onto the EVT cover can be provided by ASEAN NCAP. The artwork should be printed in full colour to at least (100 dpi) to give the correct contrast in colours of the vehicle's rear.

A.2.1 Retro- Reflective Film

Retro-reflective film is attached to the cover to replicate the reflectivity of the rear lights as shown in Figure A.2.1.1. The retro-reflective tape for the lights is produced according to the norm ECE 104. The top rear light retro- reflection film has to be in the upper middle of the car. The left and right tapes have to be affixed congruently with the normal back lights and have to look like the original ones.



Figure A.2.1.1: Front view of the EVT with the location of the retro-reflective tape

A.2.2 Radar Absorption Mat

At the impact side of the EVT, a layer of radar absorbing material is applied to the bottom of the target to replicate the shadow between the wheels. The material of the absorption mat is the

same as specified in A.1.1. The dimensions of the mat are shown in Figure A.2.2.1 with a thickness of 20 mm. The absorption mat is sewn into the EVT outer cover and is behind three layers of leather that were stuck together.

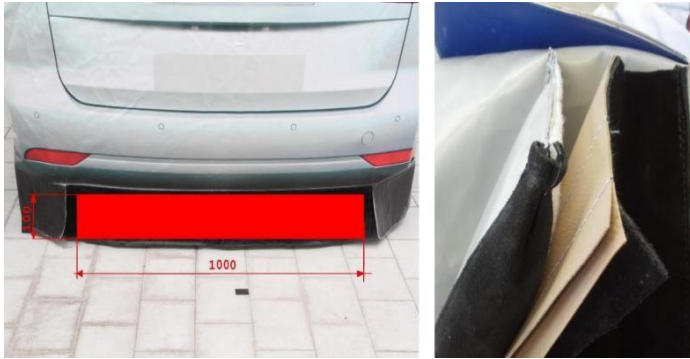

Figure A.2.2.1: Left, Front view of the EVT with the location of the lower radar absorption mat.
Right, different layers of absorption mat.

A.3 EVT Test Position

The ground clearance of the balloon structure for testing is set to 70 mm as shown in Figure A.3.1.



Figure A.3.1: Front view of the EVT showing the ground clearance.

ANNEX B

BRAKE APPLICATION PROCEDURE

The braking input characterisation test determines the brake pedal displacement and force necessary to achieve a vehicle deceleration typical of that produced by a typical real-world driver in emergency situations.

B.1 Definitions

T_{BRAKE} - The point in time where the brake pedal displacement exceeds 5 mm.

T_{-6m/s²} - The point in time is defined as the first data point where filtered, zeroed and corrected longitudinal acceleration data is less than -6 m/s^2 .

T_{-2m/s²}, T_{-4m/s²} - similar to **T_{-6m/s²}**.

B.2 Measurements

Measurements and filters are to be applied as described in Section 4 of this protocol.

B.3 Brake Characterization Procedure

First, perform the brake and tyre conditioning tests as described in 7.1.2 and 7.1.3. The brake input characterisation tests shall be undertaken within 10 minutes after conditioning the brakes and tyres.

B.3.1 Brake Displacement Characterisation Tests

- Push the brake pedal through the full extent of travel and release.

- Accelerate the VUT to a speed in excess of 85 km/h. Vehicles with an automatic transmission will be driven in D. For vehicles with a manual transmission, select the highest gear where the RPM will be at least 1500 at 85 km/h.
- Release the accelerator and allow the vehicle to coast. At a speed of 80 ± 1.0 km/h initiate a ramp braking input with a pedal application rate of 20 ± 5 mm/s and apply the brake until a longitudinal acceleration of -7 m/s^2 is achieved. For manual transmission vehicles, press the clutch as soon as the RPM drops below 1500. The test ends when a longitudinal acceleration of -7 m/s^2 is achieved.
- Measure the pedal displacement and apply force normal to the direction of travel of the initial stroke of the brake pedal, or as close as possible to normal as can be repeatedly achieved.

B.3.1.1 Perform three consecutive test runs. A minimum time of 90 seconds and a maximum time of 10 minutes shall be allowed between consecutive tests. If the maximum time of 10 minutes is exceeded, the tyre and brake conditioning procedures shall be repeated before restarting the brake pedal force characterisation tests.

- Using second order curve fit and the least squares method between $T_{-2\text{m/s}^2}$, $T_{-6\text{m/s}^2}$, calculate the pedal travel value corresponding to a longitudinal acceleration of -4 m/s^2 (=D4, unit is m). Use data from at least three valid test runs for the curve fitting.
- This brake pedal displacement is referred to as D4 in the next chapters.
- Using second order curve fit and the least squares method

between T_{-2m/s^2} , T_{-6m/s^2} , calculate the pedal force value corresponding to a longitudinal acceleration of -4 m/s^2 ($=F_4$, unit is N). Use data from at least three valid test runs for the curve fitting.

- This brake pedal force is referred to as F_4 in the next chapters.

B.3.2 Brake Force Confirmation and Iteration Procedure

- Accelerate the VUT to a speed of $80 \pm 1 \text{ km/h}$. Vehicles with an automatic transmission will be driven in D. For vehicles with a manual transmission, select the highest gear where the RPM will be at least 1500 at 80 km/h .
- Apply the brake force profile as specified in B.4, triggering the input manually rather than in response to the FCW. Determine the mean acceleration achieved during the window from $T_{\text{BRAKE}} + 1 \text{ s}$ to $T_{\text{BRAKE}} + 3 \text{ s}$. If a mean acceleration outside the range of -4 to -0.25 m/s^2 results, apply the following method to ratio the pedal force applied.

$F_{4\text{new}} = F_{4\text{original}} * (-4 / \text{mean acceleration})$, i.e. if $F_{4\text{original}}$ results in a mean acceleration of -5 m/s^2 ,
 $F_{4\text{new}} = F_{4\text{original}} * -4 / -5$

- Repeat the brake force profile with this newly calculated F_4 , determine the mean acceleration achieved and repeat the method as necessary until a mean acceleration within the range of -4 to -0.25 m/s^2 is achieved.

B.3.2.1 Three valid pedal force characteristic tests (with the acceleration level being in the range as specified) are required. A minimum time of 90 seconds and a maximum time of 10 minutes shall be allowed between consecutive tests. If the

maximum time of 10 minutes is exceeded, the tyre and brake conditioning procedures shall be repeated before restarting the brake pedal force characterisation tests. This brake pedal force is referred to as F4.

B.4 Brake Application Profile

- Detect T_{FCW} during the experiment in real-time.
- Release the accelerator at $T_{FCW} + 1$ s.
- Perform displacement control for the brake pedal, starting at $T_{FCW} + 1.2$ s with a gradient of the lesser of $5 \times D4$ or 400 mm/s (meaning the gradient to reach pedal position D4 within 200 ms, but capped to a maximum application rate of 400 mm/s).
- Monitor brake force during displacement control and use second-order filtering with a cut off frequency between 20 and 100 Hz (online) as appropriate.
- Switch to force control with a desired value of F4 when:
 - i. the value D4 as defined in B.3 is exceeded for the first time,
 - ii. the force F4 as defined in B.3 is exceeded for the first time, whichever is reached first.
- The point in time where position control is switched to force control is noted as T_{switch} .
- Maintain the force within boundaries of $F4 \pm 25\% F4$. A stable force level should be achieved within a period of 200 ms maximum after the start of force control. Additional disturbances of the force over $\pm 25\% F4$ due to further AEB interventions are allowed, as long as they have a duration of less than 200 ms.
- The average value of the force between $T_{FCW} + 1.4$ s and the end of the test should be in the range of $F4 \pm 10$ N.

Editors

Dr. Fauziana Lamin
Malaysian Institute of Road Safety Research (MIROS)

Ts. Yahaya Ahmad
Malaysian Institute of Road Safety Research (MIROS)

Ts. Nurulhana Borhan
Malaysian Institute of Road Safety Research (MIROS)

Ts. Mohd Amirudin Mohamad Radzi
Malaysian Institute of Road Safety Research (MIROS)

Ainul Bahiah Mohd Khidzir
Malaysian Institute of Road Safety Research (MIROS)

Ts. Zulhaidi Mohd Jawi
Malaysian Institute of Road Safety Research (MIROS)

Assoc. Prof. Ts. Dr. Siti Zaharah binti Ishak
Malaysian Institute of Road Safety Research (MIROS)



ASEAN NCAP PROTOCOL

2026-2030



ASEAN NCAP

c/o MIROS

**Ground Floor, Lot 127,
Jalan TKS 1,
Taman Kajang Sentral,
43000 Kajang,
Selangor, Malaysia.**



+603-8924 9200



aseanncapmedia@miros.gov.my



www.aseanncap.org



<https://www.facebook.com/AseanNcap>



<https://twitter.com/aseanncap>



<https://www.instagram.com/aseanncap>



<https://www.tiktok.com/@aseanncap>



<https://www.youtube.com/@aseanncapofficial>